

Förderrichtung

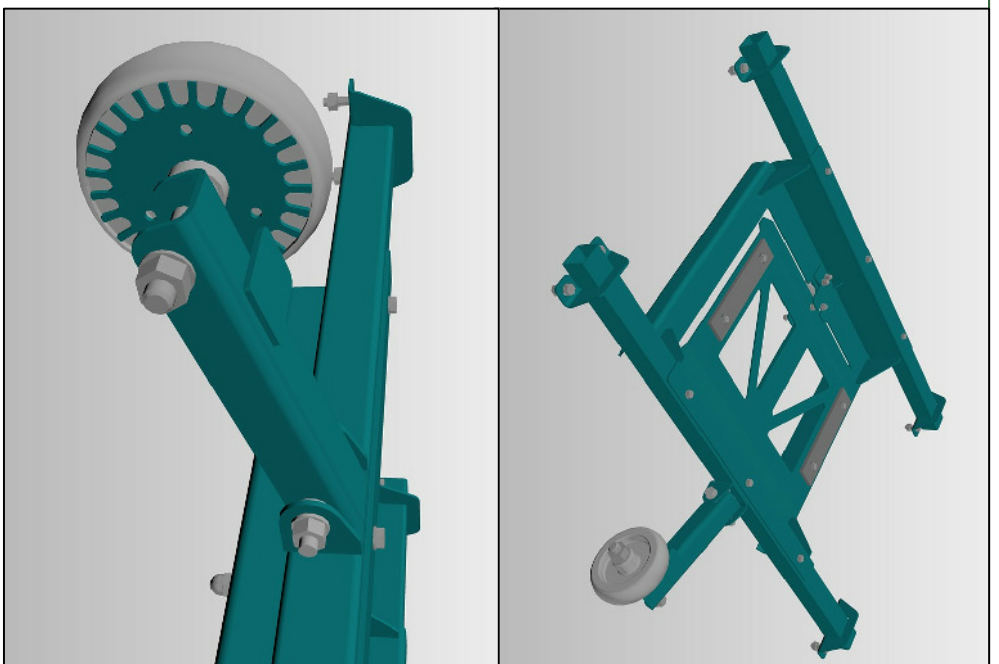

| | | |
|----------------|-------|------|
| 2014 | Datum | Name |
| Konstr. 30.01. | | CH |
| Bemaßf. 30.01. | | CH |
| Norm | | |

Com.:
BV:

M 1:10

BW-01 - Standardabmessungen

| | |
|-------|---|
| Blatt | 1 |
| Bl. | 1 |